



GCSAA Equipment Management Certificate Program

Equipment Management Certificate Program Study Guide

Equipment Management Certificate Program Level 2

Equipment Management Certificate Program
Level 2
Exam Study Guide

Contents

Equipment Mangement Certificate Program - Level 2 Exam Background.....	2
Exam Structure and Testing Requirements.....	3
Self-Evaluation	4
Categories, Competencies and Testing Objectives.....	5
Exam Sample Questions	13
Answers to Sample Questions	19
Recommended Resources	20

Equipment Management Certificate Program
Level 2
Exam Study Guide

Equipment Management Certificate Program – Level 2

Exam Background

To enhance the competency-based continuing education curriculum for Equipment Managers, GCSAA enlisted subject matter experts to define the body of knowledge (BOK) an experienced equipment manager possesses. Following psychometric principles for exam and study guide development, subject matter experts developed an exam testing experience and professional competence for equipment managers.

Successful completion of the Equipment Management Level 2 exam results in achievement of the GCSAA EMCP Level 2 certificate and demonstrates comprehensive professional competence for an equipment manager. This study guide will benefit individuals who have successfully completed EMCP Level 1, which is a pre-requisite to begin the EMCP Level 2 certificate.

The information and resources in this study guide are designed to help prospective test takers prepare for the Level 2 exam, Equipment Management Level 2. Included in this guide are the categories and associated competencies that will be tested and the specific testing objectives for this exam.

This resource will enable test takers to evaluate areas of existing proficiency and identify areas where additional study or practical experience might be needed. The guide also provides suggested resources for self-study and sample exam questions.

Study and preparation are essential components for success on any exam. However, real-world, hands-on experience is necessary to achieve competence as an experienced equipment manager. Studying alone will not adequately prepare an exam taker to pass the exam.

Equipment Management Certificate Program
Level 2
Exam Study Guide

Exam Structure and Testing Requirements

The Equipment Management Level 2 exam is online and closed-book. You will need a computer with internet access and a printer. For this exam, you may use a calculator, and it would be beneficial to have one available.

The Equipment Management Level 2 exam consists of 73 matching and multiple-choice questions that must be completed within a 2-hour and 30 minute timeframe. Exam questions may be accompanied by descriptive scenarios, illustrations, charts, graphs and other visual elements.

All Equipment Management Certificate exams must be proctored. You can use the same proctor you used for the Level 1 exams, or you can select a new proctor from one of these options:

- Golf course superintendent
- Golf course administrative personnel
- Human resources professional
- Local distributor
- School personnel
- Clergy
- Librarian
- If you have someone else in mind, contact Diana Kern at (800) 472-7878, ext. 3600 to discuss the option.

Once you have identified your proctor, that individual must contact Kern to set up the proctor username and password.

The entire exam must be completed in a single session. A passing score consists of 51 or more correct answers. Upon successful completion, you may print a personalized certificate.

If you are unsuccessful at your first attempt to pass the exam, your exam fee covers an additional attempt at no additional charge. If you are unsuccessful after both attempts, you will need to purchase the exam again for another two attempts.

Equipment Management Certificate Program
Level 2
Exam Study Guide

Self-Evaluation

In the next section are the EMCP Level 2 categories, competencies and testing objectives. As you read, score yourself on what you think your level of mastery is in each area. Label each of the objectives with a number from 1 to 5 using the following scale. 5 – I could do that in my sleep. 4 – I’m comfortable with it, but not an expert. 3 – I know the topic, but I might need help. 2 – I’m aware of the topic but haven’t ever worked with it. 1 – I’ve never seen it before.

Once you have completed your scoring, review and consider the following:

Did you score more than half the topics as a 3 or lower? If so, additional practical experience and/or mentoring may be needed for you to pass the exam.

For any category that you scored a 5, you have a strong foundation but a refresher prior to the exam would be helpful.

Anything you scored a 3 or 4, you will probably need to improve your knowledge base with additional study or hands on experience.

Equipment Management Certificate Program
Level 2
Exam Study Guide

Categories, Competencies and Testing Objectives

1. Category - Metalworking

- a. Competency – Understand how to select materials for metalworking projects
 - i. Testing Objective – Identify the consequences of using dissimilar metal fasteners.
- b. Competency – Understand the properties of shield gas
 - i. Testing Objective – Given a welding scenario, identify the type of shield gas that should be used.
- c. Competency – Understand the properties of types of welding gas
 - i. Testing Objective – Interpret the meaning of the number on a given welding rod.

2. Category – Drivetrain

- a. Competency – Diagnose and repair gear sets
 - i. Testing Objective – Given a scenario, identify the correct rotation of a gear set.
- b. Competency – Diagnose and repair axle bearings
 - i. Testing Objective – Given a picture of a failed bearing, identify why the bearing failed.
- c. Competency – Diagnose and repair typical hydraulic brake systems
 - i. Testing Objective – Given a scenario about a cart that pulls to one side when the brakes are applied, identify the cause of the behavior.

Equipment Management Certificate Program
Level 2
Exam Study Guide

3. Category – Electrical

- a. Competency – Understand the properties of different types of batteries
 - i. Testing Objective – Identify the charging properties of Lithium Ion battery.
 - ii. Testing Objective – Identify the chemical composition of various types of batteries.
- b. Competency – Understand electrical circuits
 - i. Testing Objective – Identify the components used to protect back surge in electrical circuits.
- c. Competency – Understand fusible links
 - i. Testing Objective – Identify the function and physical appearance of a fusible link.
- d. Competency – Understand voltage readings on a schematic
 - i. Testing Objective – Given a schematic and source voltage, identify the voltage reading at various points in the circuits.
- e. Competency – Understand voltage tests
 - i. Testing Objective – Identify the steps to conduct a voltage drop test.

4. Category – Engines

- a. Competency – Diagnose and repair a two-stroke cycle gasoline engine
 - i. Testing Objective – Given a picture of a failed component from 2 – cycle engine, identify the cause of the failure.
 - ii. Testing Objective – Given a picture of a failed component from 4 – cycle engine, identify the cause of the failure.

Equipment Management Certificate Program
Level 2
Exam Study Guide

- b. Competency – Understand characteristics of spark plugs
 - i. Testing Objective – Identify the disadvantage of using a lower heat-range spark plug.
- c. Competency – Understand characteristics of oil filters
 - i. Testing Objective – Identify the considerations for diesel engine oil filters.
- d. Competency – Understand the characteristics of different fuels, including gasoline, diesel, biodiesel, ethanol, propane, and mixed oil and gas.
 - i. Testing Objective – Identify the negative effects on a gas engine or a diesel engine when the wrong fuel is put into the engine.
- e. Competency – Understand Tier 4 oil specifications
 - i. Testing Objective – Identify the oil specification recommended for Tier 4 diesel engines.
- f. Competency – Understand characteristics of Plastigage
 - i. Testing Objective – Identify the purpose of Plastigage.
- g. Competency – Understand how to rebuild an engine
 - i. Testing Objective – Identify parts that can and cannot be reused when rebuilding an engine.
- h. Competency – Understand characteristics of cylinder leak down test
 - i. Testing Objective – What is the purpose of a cylinder leak down test.

5. Category – Hydraulics

- a. Competency – Understand how the mono-block valve system operates
 - i. Testing Objective – Given a scenario about a piece of equipment with a mono-block valve system that is not operating correctly, identify how to troubleshoot the problem.

Equipment Management Certificate Program
Level 2
Exam Study Guide

- b. Competency – Understand the characteristics of gear pump cases
 - i. Testing Objective – Identify situations that can cause a cracked gear pump case.
- c. Competency – Understand the characteristics of case drain test
 - i. Testing Objective – Identify the purpose of a case drain test.
- d. Competency – Understand the function of hydraulic system components from a schematic
 - i. Testing Objective – Given a troubleshooting scenario and a schematic, identify the damaged component.
- e. Competency – Understand when different gauges should be used to troubleshoot a hydraulic problem
 - i. Testing Objective – Given a scenario, identify when a pressure gauge or when a flow gauge should be used to test for a hydraulic problem.

6. Category – Cutting Units

- a. Competency – Understand the fundamentals of a reel mower
 - i. Testing Objective – Given a scenario about mowing height, identify the bedknife that should be used.
 - ii. Testing Objective – Given a scenario about decreasing the attitude of the cutting unit, identify which roller should be changed.
- b. Competency – Understanding safety issues for grinding
 - i. Testing Objective – Given a scenario about grinding, identify safety procedures that should be followed.

Equipment Management Certificate Program
Level 2
Exam Study Guide

7. Category – Spray Systems

- a. Competency – Understand sprayer maintenance
 - i. Testing Objective – Given a scenario about spraying where a calibrated sprayer runs out of liquid before anticipated, identify reasons this has occurred.
- b. Competency – Understand spreader calibration
 - i. Testing Objective – Identify critical aspects about the calibration process.
- c. Competency – Understand safety considerations about chemicals
 - i. Testing Objective – Given a scenario about a sprayer that has become inoperable, identify what to do with material in the sprayer.

8. Category – Management

- a. Competency – Manage Purchasing System
 - i. Testing Objective – Given a picture of an invoice, interpret the information on the invoice.
 - ii. Testing Objective – Given a scenario including requirements and obtaining bids, identify the bid that best meets the requirements.
- b. Competency – Manage Inventory Control System
 - i. Testing Objective – Given a scenario about equipment needs, identify the required supplies.
- c. Competency – Manage Accounting Duties and Budget
 - i. Testing Objective – Given a scenario, determine the Return on Investment (ROI).
 - ii. Testing Objective – Given a financial statement, interpret the statement.

Equipment Management Certificate Program
Level 2
Exam Study Guide

- d. Competency – Manage Conflicts
 - i. Testing Objective – Given a scenario about a human relations problem, determine how to solve the problem.
- e. Competency – Promote Ethics and Values
 - i. Testing Objective – Given a scenario identify ethics and values of employer policies.

9. Category – Turfgrass Operations

- a. Competency – Identify the impact of height of cut, frequency of clip and cutting unit setup on playability and plant health (sharpness).
 - i. Testing Objective – Given a type of turf (warm season and cool season), identify the cutting unit set up that is needed.
- b. Competency – Understand Plant Biology
 - i. Testing Objective – Given a scenario, identify the impact of maintenance operations on plant growth and health.
- c. Competency – Primary Turfgrass Practices
 - i. Testing Objective – Identify the impact of height of cut, frequency of clip and cutting unit setup on playability and plant health (sharpness).
 - ii. Testing Objective – Identify the height of cut change that will impact after cut appearance issues.
 - iii. Testing Objective – Identify the benefits of sand topdressing.
 - iv. Testing Objective – Identify common turf diseases and pest damage.
 - v. Testing Objective – Identify biotic and abiotic turf damage given pictures of the damage.

Equipment Management Certificate Program
Level 2
Exam Study Guide

- d. Competency – Comprehend Environmental Impacts
 - i. Testing Objective – Identify environmental terminology and practices for the golf facility (Government agency, Energy Star, LEED, BMP, IPM, etc.)
 - ii. Testing Objective – Identify, determine, and document environmental issues.

10. Category – Best Management Practices

- a. Competency – Best Management Practices – Equipment Management
 - i. Testing Objective – Identify why equipment should have an assigned parking area according to Best Management Practices.
 - ii. Testing Objective – Identify the Best Management Practices for cleaning equipment.
 - iii. Testing Objective – Identify the type of mower recommended in Best Management Practices for different heights of turf.
 - iv. Testing Objective – Identify Best Management Practices for disposing of solvents and degreasers.
 - v. Testing Objectives – Identify the steps to respond to a spill in the shop.
- b. Competency – Best Management Practices – Understand Pest Management
 - i. Testing Objective – Identify pictures of correctly stored pesticide and fertilizer according to the Best Management Practices.
 - ii. Testing Objective – Identify the correct height of storage for pesticides and fertilizer according to Best Management Practices.

Equipment Management Certificate Program
Level 2
Exam Study Guide

- c. Competency – Best Management Practices – Manage Primary Turfgrass Practices
 - i. Testing Objective - Identify the goals of cultivation practices such as aerification and verticutting according to Best Management Practices.
 - ii. Testing Objective – Identify how to reduce excessive thatch or organic matter according to Best Management Practices.
 - iii. Testing Objective – Identify the benefits of rolling greens.

Equipment Management Certificate Program
Level 2
Exam Study Guide

Exam Sample Questions

Below are 14 sample questions from the Equipment Management Level 2 exam. These exact questions will not appear on the exam. However, they will provide exam takers an idea on what to expect regarding the format of the questions and the level of difficulty.

Question 1

A technician is using a welding rod with the numbers 7018 at the end.

What is the correct welding position?

- a. All positions
- b. Flat and overhead position only
- c. Flat and horizontal position only
- d. Vertical and overhead position only

Question 2

A utility cart veers hard to the right when the four-wheel hydraulic brakes are applied.

What is the problem with this cart?

- a. The front brake pads are worn.
- b. The left front caliper piston has seized.
- c. The master cylinder is internally leaking.
- d. The right rear brake shoes are sticking open.

Equipment Management Certificate Program
Level 2
Exam Study Guide

Question 3

Given the following schematic:

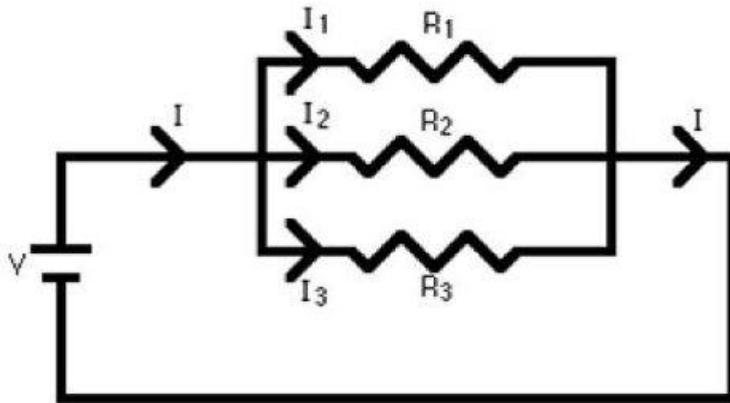

Using the following information, measure each resistor to determine the correct voltage:

- There are 3 amps in the circuit
- R_1 is 1 ohms
- R_2 is 4 ohms
- R_3 is 3 ohms

Match each resistor – R_1 , R_2 , and R_3 – to the correct voltage.

- | | |
|---------------|--------------|
| 1. R_1 ____ | A – 3 volts |
| | B – 6 volts |
| 2. R_2 ____ | C – 9 volts |
| | D – 12 volts |
| 3. R_3 ____ | E – 15 volts |
| | F – 24 volts |

Equipment Management Certificate Program
Level 2
Exam Study Guide

Question 4

What is a disadvantage of using a lower than recommended heat-range spark plug?

- a. Engine will run hot or overheat.
- b. Engine will fail to reach operating temperature.
- c. Pre-ignition or detonation and damage can occur.
- d. Excessive fouling from insufficient burn temperature.

Question 5

A cutting unit utilizes a fixed reel position, adjustable bedknife, and rear roller height-of-cut adjustments. The cutting unit has developed reel and bedknife wear, and the reel has become smaller in diameter.

What is likely to happen to the attitude of the cutting unit under these conditions?

- a. The attitude will increase causing the cutting unit to be less aggressive.
- b. The attitude will increase causing the cutting unit to be more aggressive.
- c. The attitude will decrease causing cutting unit to be less aggressive.
- d. The attitude will decrease causing the cutting unit to be more aggressive.

Question 6

Which nozzle material will be the least durable on a sprayer?

- a. Nylon
- b. Brass
- c. Stainless Steel
- d. Hardened stainless steel

Equipment Management Certificate Program
Level 2
Exam Study Guide

Question 7

A local Golf Club is considering replacing their 30-year old constant speed pump station to a new Variable Speed Drive (VFD) station. The new pump station would cost \$175,000. The current station's yearly electrical expense is \$375,000 and yearly repair and maintenance (R/M) cost is \$30,000. The new VFD system would reduce the electrical cost by 30% and the R/M cost to \$2,500.

How long would it take to achieve the ROI for replacing the pump station?

- a. 0.16 years
- b. 1.25 years
- c. 2.14 years
- d. 4 years

Question 8

An individual in a new administrative position is concerned that the staff is unmotivated and underperforming.

Which practice should be implemented?

- a. Provide praise and positive feedback
- b. Immediately terminate all underperforming employees
- c. Reprimand underperforming employees in front of other employees
- d. Ensure that all employees know the administrator is the decision maker

Question 9

Which organism causes fairy ring?

- a. Worm
- b. Fungi
- c. Insect
- d. Bacteria

Equipment Management Certificate Program
Level 2
Exam Study Guide

Question 10

Given this picture of turf:



Which type of abiotic damage is present?

- a. Tire Scuff
- b. Mower Scalp
- c. Brown Patch
- d. Pythium Blight

Question 11

Which organization manages the Energy Star® program, according to the GCSAA's Best Management Practices Guide?

- a. International Energy Agency
- b. U.S. Department of Commerce
- c. Canadian Conservation Institute
- d. U.S. Environmental Protection Agency

Equipment Management Certificate Program
Level 2
Exam Study Guide

Question 12

According to GCSAA's Best Management Practices, which type of mower is recommended for the best quality of cut for turfgrass over 1" in height?

- a. Reel
- b. Flail
- c. Sickle
- d. Rotary

Question 13

According to GCSAA's Best Management Practices, which topdressing schedule is best for playing surfaces, thatch, and underlying soils?

- a. Light and frequent
- b. Heavy and frequent
- c. Light and infrequent
- d. Heavy and infrequent

Question 14

According to GCSAA's Best Management Practices, which item will be reduced by using verticutting?

- a. Grain
- b. Germination
- c. Soil Compaction
- d. Fertilizer rates

Equipment Management Certificate Program
Level 2
Exam Study Guide

Answers to Sample Questions

1. A
2. B
3. R1, A; R2, D; R3, C
4. D
5. C
6. B
7. B
8. A
9. B
10. A
11. D
12. D
13. A
14. A

Equipment Management Certificate Program

Level 2

Exam Study Guide

Recommended Resources

The following resources will be beneficial in preparing for the exam. These resources are not the sole source of exam content. Practical work experience is recommended to successfully complete the exam.

GCSAA On-Demand Webinars

For the most current listing and to access webinars, visit [GCSAA's Learning Hub](#) and select category EMCP Exam Prep

Preparing for the GCSAA EMCP Exams: Electrical Systems and Drivetrain Systems

Preparing for the GCSAA EMCP Exams: Metalworking and Fabrication/Spray Systems

Equipment Management Certificate Program 101

Other Resources

American Petroleum Institute, *Latest Oil Categories*. Retrieved from www.api.org

Battery University., *Battery Building Blocks*. (2018). Retrieved from www.batteryuniversity.com

Bell, Terence, The Balance. (2018). *What Are the Different Types of Corrosion?*
www.thebalance.com

Bobs Shop. (2012, April 4). *Small Engine Maintenance*. Retrieved from
www.golfcoursemechanics.blogspot.com

Business Basics. *Calculating Costs*. Retrieved from <http://busbasics.weebly.com/calculating-costs.html>

Car pulls to the left or right when braking? Get your car inspected at your home or office.
Retrieved from www.yourmechanic.com

Common Causes of Bearing Failure. Retrieved from www.applied.com

Core Charges. *What is a core charge?* Retrieved from www.advanceautoparts.com

Christians, Nick E., *Fundamentals of Turfgrass Management*

Cleveland, Cleve, CGCS, *A Financial Short Course*

Equipment Management Certificate Program
Level 2
Exam Study Guide

Foley United., ACCU-600 Spin / Relief Reel Mower Grinder., Retrieved from www.foleyunited.com

GCSAA., and USGA., *BMP: Best Management Practices, Where Leadership & Action Intersect.*, Retrieved from [www.gcsaa.org/BMP Planning Guide](http://www.gcsaa.org/BMP%20Planning%20Guide)

GCSAA., Professional Conduct Guidelines., Retrieved from www.gcsaa.org

GCSAA., *Equipment Management Certificate Program Study Guide: Cutting Units: Theory, Operation and Maintenance*

GCSAA., *Equipment Management Certificate Program Study Guide: Drive Systems: Theory, Operation and Maintenance*

GCSAA., *Equipment Management Certificate Program Study Guide: Electrical Systems: Theory and Operation*

GCSAA., *Equipment Management Certificate Program Study Guide: Fundamentals of Turfgrass Operations*

GCSAA., *Equipment Management Certificate Program Study Guide: Hydraulic Systems: Theory, Operation and Maintenance*

GCSAA., *Equipment Management Certificate Program Study Guide: Internal Combustion Engines: Theory Operation and Maintenance*

GCSAA., *Equipment Management Certificate Program Study Guide: Metalworking and Fabrication*

GCSAA., *Equipment Management Certificate Program Study Guide: Spray Systems: Calibration, Operation and Maintenance*

Giordano, P. R., Vargas, J. M., Jr., Ph.D., Nikolai, T. A., Ph.D., & Hammerschmidt, R., Ph.D. (2012, February). *Why lightweight rolling decreases dollar spot.* Retrieved from www.turf.unm.edu

Hydrolock. (2018, July). Retrieved from <https://en.wikipedia.org/wiki/Hydrolock>

Indeed. *How to Write a Job Description.* Retrieved from www.indeed.com

Lincoln Electric | *AWS Classifications Explained.* Retrieved from www.lincolnelectric.com

Equipment Management Certificate Program
Level 2
Exam Study Guide

Leak Down Test. (2018, June 19). Retrieved from www.repairpal.com

Merullo, V.D., & Valentine, M.J. (1992). *Arboriculture & the law*. Savoy, IL: International Society of Arboriculture.

[Michigan Turfgrass Foundation](http://www.msuturfinsects.net), www.msuturfinsects.net

Milligan, Robert, A., and Thomas, Maloney, R., *Human Resource Management for Golf Course Superintendents*

Net D. (2018, August 13). Retrieved from https://en.wikipedia.org/wiki/Net_D

Noria Corporation. www.machinerylubrication.com

Schmidgall, Raymond S., *Superintendent's Handbook of Financial Management (Revised, Edition)*

Sears. (2018). *What Happens If You Put Diesel in a Gas Engine?* Retrieved from www.sears.com

The Toro Company. *Education and Technical References/ Service Training Guides*. Retrieved from <https://www.toro.com/en>

The Toro Company. (2017). *Aftercut Appearance Troubleshooting Guide*. Retrieved from <http://www.turfproductscorp/online> PDF

The Toro Company. *Reel Mower Basics (with sharpening guides)*. Retrieved from <https://cdn2.toro.com>

The Toro Company. *Reelmaster® 6500-D*. Retrieved from <https://media.toro.com/servicemanuals/01084sl.pdf>

The Toro Company. *Stock Up on Parts to Keep Routine Maintenance Truly Routine*. (2013, April 24). Retrieved from www.toroadvantage.com

The Toro Company. *Reelmaster® 3100-D Traction Unit*. Retrieved from www.toro.com

The Toro Company. *Greensmaster® 3150 2-Wheel Drive Traction Unit*. Retrieved from www.manuals.toro.com

Equipment Management Certificate Program
Level 2
Exam Study Guide

United States of Golf Association, and Soller, Derf, (2013). *Golf Course Maintenance Equipment 101, is your golf facility equipped for the past or the present?*
www.gsrpdf.lib.msu.edu